

# Product Specification Datasheet

TNDD13AXM-CD500

## 400G QSFP-DD DR4 Optical Transceiver



### Functional Description

This product is a 400Gb/s QSFP-DD optical module designed for 0.5 km optical communication applications. The module converts 8 channels of 50Gb/s (PAM4) electrical input data to 4 channels of parallel optical signals, each capable of 100Gb/s operation for an aggregate data rate of 400Gb/s.

On the receiver side, the module converts 4 channels of parallel optical signals of 100Gb/s each channel for an aggregate data rate of 400Gb/s into 8 channels of 50Gb/s (PAM4) electrical output data.

An optical fiber cable with an MTP/MPO-12 connector can be plugged into the QSFP-DD DR4 module receptacle. Host FEC is required to support up to 0.5Km fiber transmission.

The Trustnuo transceiver is based on proprietary Trustnuo PLC technology, using surface mounted opto-electronic devices with no free space elements. The unique design of the optical engine facilitates unparalleled compactness while maintaining Telcordia robustness.

### Applications

- 400G Ethernet
- Data Center Interconnect
- Infiniband Interconnect
- Enterprise Networking

### Features

- Compliant to QSFP-DD MSA
- Parallel 4 Optical Lanes
- IEEE 802.3bs 400GBASE-DR4 Specification compliant
- Maximum power consumption 9.5W

### General Description

- Compliant with IEEE Std 802.3bs
- Compliant with 400G-DR4 optical specifications
- Compliant with QSFP-DD MSA
- Compliant with CMIS4.0 Management interface specifications
- 8x53.125Gb/s electrical interface (400GAUI-8)
- Up to 0.5km transmission on single mode fiber (SMF) with FEC
- Single +3.3V power supply
- Case temperature range: 0 ~ +70°C
- Maximum power consumption 9.5W
- RoHS complaint

Confidential

#### Absolute Maximum Ratings

Parameter	Symbol	Min	Max	Units
Storage Temperature Range	T <sub>STG</sub>	-40	+85	°C
Supply Voltage	V <sub>CC</sub>	0	4	V
Relative Humidity	RH	10% to 90% non-condensing		

#### Operating Conditions

Parameter	Symbol	Min	Max	Units
Case Temperature- Operating	T <sub>CASE</sub>	0	70	°C
Supply Voltage	V <sub>CC</sub>	3.14	3.46	V
Power Consumption	P <sub>DISS</sub>		9.5	W
Pre-FEC Bit Error Ratio			2.4x10 <sup>-4</sup>	
Post-FEC Bit Error Ratio			1x10 <sup>-12</sup>	
Link Distance		2	500	M

### Wavelength Lane Assignments

Transmitter Parameter	Min	Typical	Max	Units
Lane Wavelength Range	1304.5	1311	1317.5	nm

### Transmitter Optical Specifications

Transmitter Parameter	Min	Typical	Max	Units
Lane Wavelength Range	1304.5		1317.5	nm
Modulation Format	PAM4			
Average Optical Power per lane	-2.9		4	dBm
Outer Optical Modulation Amplitude (OMA <sub>outer</sub> ), each lane	-0.8		4.2	dBm
Average Launch Power per Lane @ TX Off State			-15	dBm
Launch Power in OMA <sub>outer</sub> minus TDECQ, each Lane	-2.2			dB
Transmitter and Dispersion Eye Closure for PAM4, each Lane			3.4	dB
Extinction Ratio	3.5			dB
Relative Intensity Noise (OMA)			-136	dB/Hz
Side-Mode Suppression Ration (SMSR)	30			dB
Optical Return Loss Tolerance			21.4	dB
Transmitter Reflectance			-26	dB

### Receiver Optical Specifications

Receiver Parameter	Min	Typical	Max	Units
Lane Wavelength Range	1304.5		1317.5	nm
Modulation Format	PAM4			
Damage Threshold	5.0			dBm
Average Receive Power, each lane	-5.9		4.0	dBm
Receiver Power, each lane (OMA)			4.2	dBm
Receiver Reflectance			-26.0	dB
Receiver Sensitivity each lane (OMA <sub>outer</sub> )			-4.4	dBm
Stressed Receiver Sensitivity (OMA <sub>outer</sub> ), each			-1.9	dBm
Stressed Conditions for Stress Receiver Sensitivity				
Stressed Eye Closure for PAM4 (SECQ), Lane under Test		3.4		dB
OMA <sub>outer</sub> of each Aggressor Lane		4.2		dBm

### High Speed Electrical Specifications

Parameter	Min	Typical	Max	Units	Notes
<b>Receiver electrical output characteristics at TP4</b>					
Signaling rate per lane		26.5625		GBd	
AC common-mode output voltage(RMS)		-	17.5	mV	
Differential peak-to-peak output voltage			900	mV	
Near-end ESMW (Eye symmetry mask width)		0.265		UI	
Near-end Eye height, differential	70			mV	
Far-end ESMW (Eye symmetry mask width)		0.2		UI	
Far-end Eye height, differential	30			mV	
Far-end pre-cursor ISI ratio	-4.5		2.5	%	
Differential output return loss	9.5 - 0.37f			dB	0.01 – 8 GHz
	4.75 - 7.4log 10 (f/14)			dB	8 – 19 GHz
Common to differential mode conversion return loss	22-20(f/25.78)			dB	0.01 -12.89GHz
	15 -6log 10 (f/25.78)			dB	12.89 – 19 GHz
Differential termination mismatch			10	%	
Transition time (min, 20% to 80%)	9.5			ps	
DC common mode voltage	-350		2850	mV	
<b>Transmitter electrical input characteristics at TP1</b>					
Signaling rate, per lane		26.5625		GBd	
Differential pk-pk input voltage tolerance	900			mV	
Differential input return loss	9.5 - 0.37f			dB	0.01 – 8 GHz
	4.75 - 7.4log 10 (f/14)			dB	8 – 19 GHz
Differential to common mode input return loss	22-20(f/25.78)			dB	0.01 -12.89GHz
	15 -6log 10 (f/25.78)			dB	12.89 – 19 GHz
Differential termination mismatch			10	%	
Module stressed input test	Per Section 120E.3.4.1, IEEE802.3bs				
Single-ended voltage tolerance range	-0.4		3.3	V	
Common-mode voltage	-350		2850	mV	

### Receiver Output Power Thresholds for Loss of Signal (LOS)

Parameter	Min	Typical	Max	Units
RX_LOS_Assert Min/Max	-15.0			dBm
RX_LOS_De-Assert Min/Max			-8.9	dBm
RX_LOS_Hysteresis		1.5		dB

### Digital Diagnostic Monitoring Specifications

Parameters	Unit	Specification
Temperature Monitor absolute error	degC	± 3
Voltage Monitor absolute error	%	± 5
I_bias Monitor absolute error	%	± 10
Received Power (Rx) Monitor absolute error	dB	± 3.0
Transmit Power (Tx) Monitor absolute error	dB	± 3.0

### QSFP-DD Edge Connector and Pinout Description

The electrical pinout of the QSFP-DD module is shown in Figure 2 below.

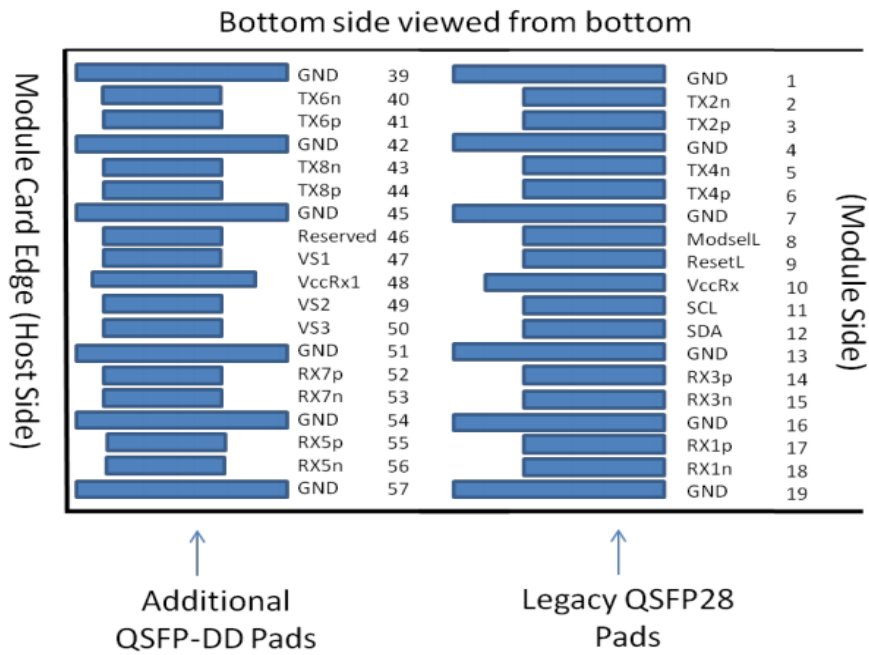
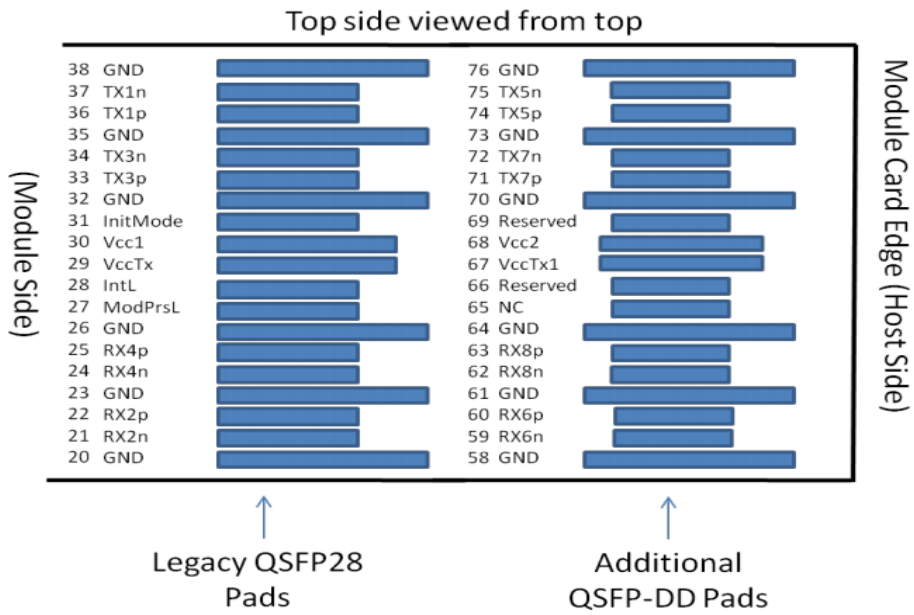
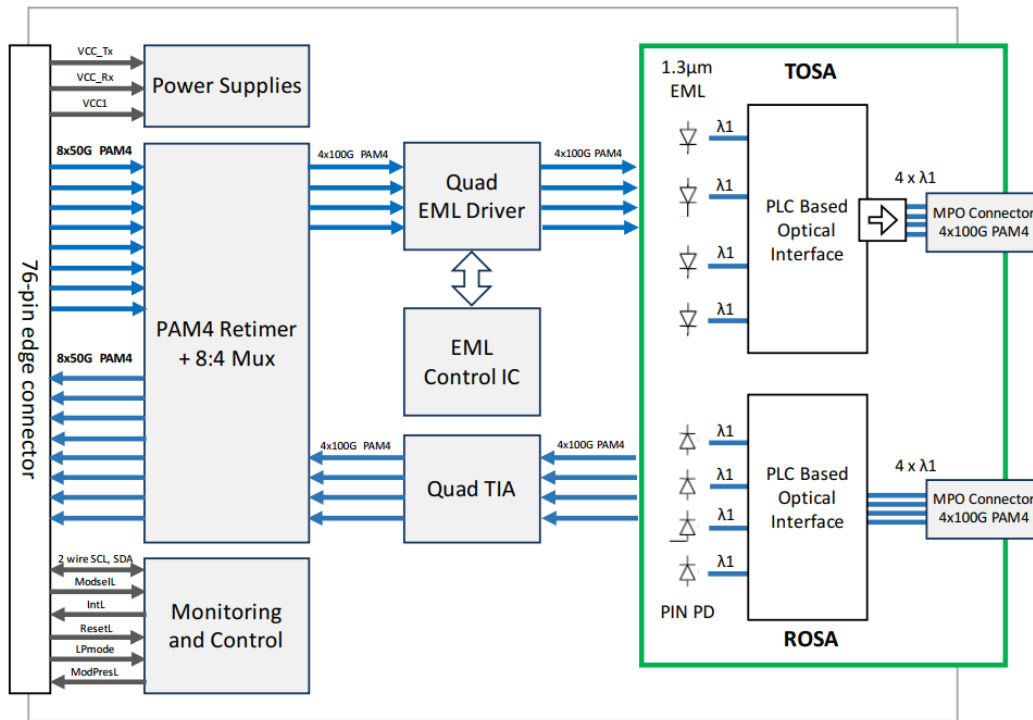

Figure 1. Host PCB QSFP-DD pad assignment top view

Pin	Symbol	Description	Note
1	GND	Ground	1
2	Tx2	Transmitter Inverted Data Input	
3	Tx2	Transmitter Non-Inverted Data output	
4	GND	Ground	1
5	Tx4	Transmitter Inverted Data Input	
6	Tx4	Transmitter Non-Inverted Data output	
7	GND	Ground	1
8	ModSelL	Module Select	
9	Reset	Module Reset	
10	VccRx	3.3V Power Supply Receiver	2
11	SCL	2-Wire serial Interface Clock	
12	SDA	2-Wire serial Interface Data	
13	GND	Ground	1
14	Rx3p	Receiver Non-Inverted Data Output	
15	Rx3n	Receiver Inverted Data Output	
16	GND	Ground	1
17	Rx1p	Receiver Non-Inverted Data Output	
18	Rx1n	Receiver Inverted Data Output	
19	GND	Ground	1
20	GND	Ground	1
21	Rx2n	Receiver Inverted Data Output	
22	Rx2p	Receiver Non-Inverted Data Output	
23	GND	Ground	1
24	Rx4n	Receiver Inverted Data Output	
25	Rx4p	Receiver Non-Inverted Data Output	
26	GND	Ground	1
27	ModPrsL	Module Present	
28	IntL	Interrup	
29	VccTx	3.3V power supply transmitter	2
30	Vcc1	3.3V power supply	2
31	Init Mode	Initialization mode	
32	GND	Ground	1
33	Tx3p	Transmitter Non-Inverted Data Input	
34	Tx3n	Transmitter Inverted Data Output	
35	GND	Ground	1
36	Tx1p	Transmitter Non-Inverted Data Input	
37	Tx1n	Transmitter Inverted Data Output	
38	GND	Ground	1

39	GND	Ground	1
40	Tx6n	Transmitter Inverted Data Input	
41	Tx6p	Transmitter Non-Inverted Data output	
42	GND	Ground	1
43	Tx8n	Transmitter Inverted Data Input	
44	Tx8p	Transmitter Non-Inverted Data output	
45	GND	Ground	1
46	Reserved	For Future Use	3
47	VS1	Module Vendor Specific 1	3
48	VccRx1	3.3V Power Supply	2
49	VS2	Module Vendor Specific 2	3
50	VS3	Module Vendor Specific 3	3
51	GND	Ground	1
52	Rx7p	Receiver Non-Inverted Data Output	
53	Rx7n	Receiver Inverted Data Output	
54	GND	Ground	1
55	Rx5p	Receiver Non-Inverted Data Output	
56	Rx5n	Receiver Inverted Data Output	
57	GND	Ground	1
58	GND	Ground	1
59	Rx6n	Receiver Inverted Data Output	
60	Rx6p	Receiver Non-Inverted Data Output	
61	GND	Ground	1
62	Rx8n	Receiver Inverted Data Output	
63	Rx8p	Receiver Non-Inverted Data Output	
64	GND	Ground	1
65	NC	No Connect	3
66	Reserved	For Future Use	3
67	VccTx1	3.3V power supply	2
68	Vcc2	3.3V power supply	2
69	Reserved	For Future Use	3
70	GND	Ground	1
71	Tx7p	Transmitter Non-Inverted Data Input	
72	Tx7n	Transmitter Inverted Data Output	
73	GND	Ground	1
74	Tx5p	Transmitter Non-Inverted Data Input	
75	Tx5n	Transmitter Inverted Data Output	
76	GND	Ground	1

### Module Block Diagram



### Mechanical Specifications

Pull tab color: Blue  
 Pantone: 300U

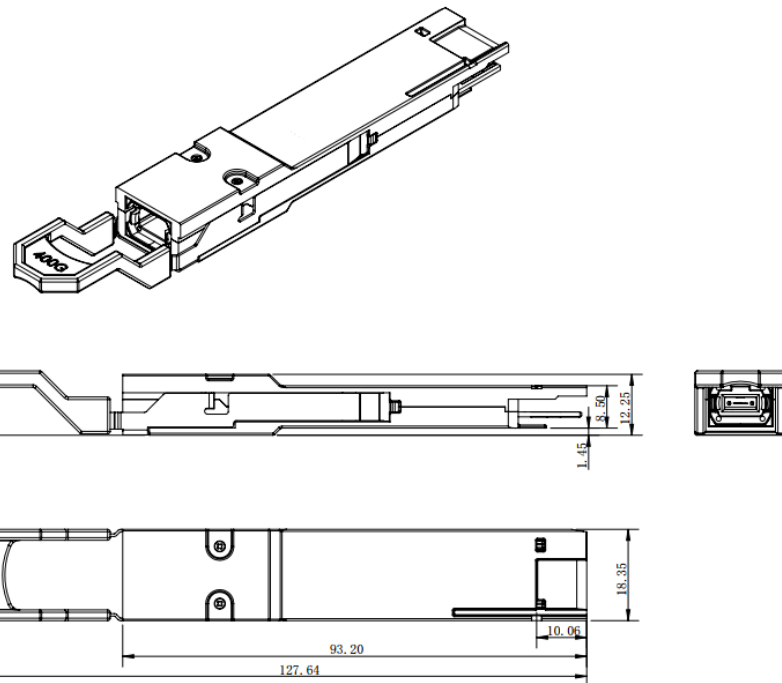

### Order information

Part Number	Description
TNDD13AXM-CD500	QSFPDD 400G DR4 Optical Transceiver